



**MITSUBISHI  
MOTORS**

Drive your Ambition



# OUTLANDER

# LIVE OUTLANDISH



## Outlander, built for the time of your life.

Since 1917 Mitsubishi Motors has been at the forefront of technological innovations. Having launched the inventive Super Select 4WD system and the world's first Plug-in hybrid electric SUV, our vehicles have been tested and triumphant on some of the world's toughest terrains including the Dakar rally. These engineering milestones, together with our commitment to reliability and ingenuity sets us apart. As we continue to move forward, pushing the boundaries of innovations, you can rest assured your Mitsubishi has been built for the time of your life.



# OUTLANDER

## STYLED TO SET YOU APART.

Do your thing and do it in outlandish style. Completely reimagined, redesigned and redefined, the all-new Mitsubishi Outlander and Outlander Plug-in Hybrid EV gives you the freedom to be yourself, wherever you want to be.

With cutting edge features and rally bred performance built into their DNA, the bigger, bolder next generation Outlander is nothing short of revolutionary. Their powerful presence, impressive stance and state of the art technology inspire confidence wherever the journey takes you. Dare to be different. Go there.



# THE EV SUPERPOWER



Mitsubishi has been leading the charge in electric vehicle technology for more than 50 years. The all-new, more powerful Outlander Plug-in Hybrid EV gives you the best of both worlds with a highly advanced and eco-friendly powertrain that combines both electric motors and a hybrid petrol engine.

Its striking style will always make an impression, but not an impact. Outlander Plug-in Hybrid EV's next generation battery technology and electric motors now deliver up to 54% more electric driving range, so you can go even further with zero tailpipe emissions. Plus, you can use hybrid petrol power for longer road trips with remarkable fuel efficiency.

Mitsubishi Plug-in Hybrid EVs offer everything their petrol-only counterparts do, they just do it with the added option of electric power. With a class leading 84km all electric range<sup>^</sup> and the long range reassurance of a hybrid petrol engine, just pick a destination and enjoy the great outdoors with even greater distance.

## Lead the Charge.

The new Outlander Plug-in Hybrid EV is equipped with a larger fuel tank (56L) and greater battery capacity (20kWh), so it can deliver more power wherever and whenever you need it.

All models can be charged at home or on the road. For home charging, simply connect the vehicle to a regular domestic power socket using the supplied cable. For faster home charging, you can install an optional Level 2 AC fast charger. When charging at a public rapid recharging station, you can reach an 80% battery capacity in just 38 minutes.

When you're driving, the Outlander Plug-in Hybrid EV starts charging itself by using regenerative braking technology and harnessing power generated by the hybrid petrol engine.

<sup>^</sup>Based on sample vehicle tested in accordance with ADR 81/02. Actual results will vary depending on traffic conditions, vehicle condition and driving style. Lithium-ion cells degrade over time, and any decrease in battery capacity will reduce electric range.

# OUTLANDER

## PLUG-IN HYBRID EV

### POWER TO CHOOSE. POWER TO YOU.

The Outlander Plug-in Hybrid EV uses two small and lightweight high-powered motors in the front and rear to deliver smooth driving and instant acceleration performance only an electric system can provide.

While mainly running on motor power, the vehicle can also seamlessly switch to engine power in response to battery and driving conditions. So there's no need to worry about remaining charge levels.



### EV Driving



**EV DRIVE MODE**  
Quiet and exceptionally clean, EV driving is perfect for low to medium speeds in urban areas.

### Hybrid Driving



**SERIES HYBRID MODE**  
When accelerating or climbing hills, the hybrid petrol engine can be used to generate additional power while the vehicle runs on motor power.



**PARALLEL HYBRID MODE**  
For high-speed driving such as overtaking vehicles on the highway, the vehicle runs on engine power while being assisted by the motor.

# FULLY EMPOWERED



Inside the Outlander Plug-in Hybrid EV's luxuriously appointed cabin, you're immediately surrounded by sophistication and innovation.

The Outlander Plug-in Hybrid EV acts as a mobile battery, offering a power source when needed for outdoor activities like camping or in emergency situations such as a blackout\*. Both the centre console and the boot have standard power points,† with a maximum load of 1500W combined. This is enough to support electrical equipment and appliances like a laptop, hair dryer, hot plate, kettle, phone charger and much more.

Directly in front of you is the 12.3" digital driver display screen that provides all your vital driver information and a clear visual representation of the road surface you choose on the drive mode selector.

The high-definition head-up display system\* is a game-changer, projecting real time vehicle information directly onto the windscreen. Its eyeline can be adjusted to suit individual drivers.

All you'll hear is the pure silence of twin electric motors as a host of innovative technologies instantly link to ensure everyone's safety.

The Outlander Plug-in Hybrid EV also features a user adjustable single-pedal mode which allows acceleration and deceleration to be controlled by the accelerator pedal alone, providing easier driving operation with less pedal-change.

\*With an approved Bi-directional Electric Vehicle Supply (EVSE), sold separately to the vehicle.

†Excludes ES models.







# BUILT TO SET YOU FREE



The daring and distinct Mitsubishi Outlander is no wallflower. It makes a strong, dignified entrance with confident sculpted lines, muscular flared fenders and broad shoulders. Its bold front dynamic shield and streamlined rear spoiler not only turn heads, they also deliver greater performance and aerodynamics.

Agile and adventurous, the completely reimagined and meticulously redesigned Outlander stands proud with a wider and more dynamic front face, edgier sculptured sides, a horizontal rear design and authoritative 20-inch alloy wheels\*.

\*Aspire, Exceed, Exceed Tourer & GSR models only.

## Have an open mind.

The new Outlander's larger and wider panoramic sunroof goes above and beyond. One touch tilt and slide operation opens up the interior cabin to the great outdoors, creating an even greater sense of vast, natural space.

# EXCEED YOUR EXPECTATIONS



Once you ease into Outlander Exceed Tourer's exceptionally crafted cabin, you'll instantly relax and unwind. Fastidious attention to detail has been paid to every nuance and feature, right down to the knobs and dials. Advanced human-centric design through the multi-function steering wheel will reassure with simple, intuitive control. Contrasting two-tone black and saddle tan leather upholstery, striking aluminium instrument panel accents and matte carbon trim make a distinguished statement in style.

On the road, a superior combination of exquisite craftsmanship and advanced technology will make you feel at home. An 8-way power adjustable driver and front passenger seat can be customised and memorised to embrace and cradle any body and height.

Accented Diamond stitched leather upholstery coalesces with embedded comfort features including a massage function in both front seats, so you always arrive relaxed. Heated seats in the front and rear provide welcome winter warmth, while independent tri-zone climate control allows everyone to create their own personal oasis year round.





# CHANGE THINGS UP



Outlander's luxurious interior not only offers generous head and legroom, it's incredibly accommodating in more ways than one. With 5 or 5+2 seat flexibility, it provides ample room for busy weeks and even bigger weekends away. All seats can recline for added comfort, while the slide adjustable 40:20:40 split second row and 50:50 split rear third row\* can fold fully forward to

create a multitude of versatile passenger and cargo configurations. All rear seats can lie flat to create a capacious luggage area with loads of cargo space. Under floor storage available in some models adds even more stowage and seating options.

# OUT THERE. IN TOUCH.



A wireless smartphone charging tray\* means the entertainment or handsfree conversations never have to stop.

Mitsubishi's Smartphone-link Display Audio with 9-inch\* touchscreen display brings all the fun with you, allowing you to take all the latest smartphone apps on the road with Apple CarPlay or Android Auto™.

## March to the beat of your own drum, or playlists.

Go loud and proud. Sound insulating double pane windows and windshields ensure silence is golden, so you can hear every note played through the Outlander Exceed and Exceed Tourer's incredible acoustically tuned 10-speaker Bose® sound system<sup>†</sup>.

## The tailgate that's one step ahead.

As equally convenient as it is impressive, the Outlander's automatic power tailgate can be opened simply by placing a foot under its rear bumper<sup>‡</sup>. Its lift height is adjustable to prevent contact with low garage doors and ceilings, while a wider rear frame and deeper cavity easily accommodate bulky luggage and equipment.

# FORGE YOUR OWN PATH

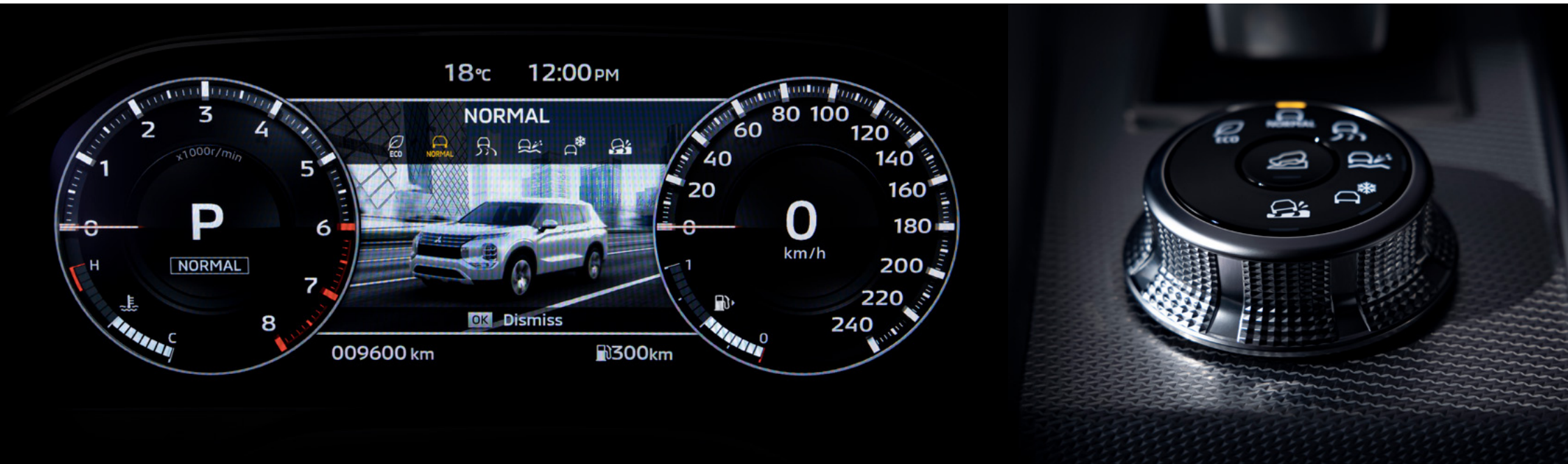

A high-resolution 12.3-inch full digital driver display\* continuously updates the status of your Outlander and can be customised to showcase the Outlander's built in satellite navigation, Super All-Wheel Control information, audio entertainment options, and many more important details.

The driver's windscreen projection 10.8-inch head up display\* can be configured to provide additional information within the driver's field of view without taking your eyes of the road.

Outlander's Super-All Wheel Control system uses Mitsubishi's revolutionary rally bred 4WD based technology. Featuring direct coupling with quick torque response, it optimises drive and braking force at each wheel to deliver more power, better cornering and greater stability wherever you are. The drive mode selector allows the driver to adjust the chassis control system to suit the conditions. There are 5 drive modes for 2WD, 6 drive modes for S-AWC models and 7 modes for Plug-in Hybrid EV models.

#### **Normal mode**

Optimal performance for everyday use.

#### **Eco Mode**

Provides ecological and economic driving.

#### **Tarmac Mode**

For agile and fun driving on dry sealed surfaces.

#### **Gravel Mode**

Superior handling on loose surfaces for maximum control.

#### **Snow Mode**

Enhances stability on slippery or icy road conditions.

#### **Mud Mode (AWD only)**

Provides powerful all wheel driving in muddy conditions.

#### **Power Mode (Plug-in Hybrid EV only)**

Provides exciting and responsive acceleration.

\*Excludes ES, LS and Aspire petrol models. +Excludes ES and LS models.



**GUIDE. PROTECT. CONNECT.**

# MiTEC

Mitsubishi Motors Intuitive Technology or MiTEC, is an integrated system<sup>^</sup> of brilliant innovations in action, working in unison to guide and protect, alert and connect, even entertain. It thinks like you, reacts like you, before you even know it. MiTEC delivers unsurpassed safety and next generation features to the modern-day driver.





### **Rear Cross Traffic Alert<sup>1</sup>**

Rear Cross Traffic Alert system uses the rear side radar sensors to detect another vehicle approaching from the side when reversing. The system operates when the vehicle is in reverse at speeds below 8km/h. It can detect an approaching vehicle from approx. 20m away, alerting the driver via an audible chime and blinking BSW warning light in the side mirror.

### **Rear Automatic Emergency Braking<sup>1</sup>**

Rear Automatic Emergency Braking system uses the rear parking sensors to detect obstacles behind the vehicle. If a risk of a collision with an obstacle is detected, audible and visual warnings are given and the system will automatically apply the brakes. Operates when vehicle is in reverse at speeds below 15km/h.

### **Lane Departure Warning**

Lane departure Warning uses front camera to issue an alert if the vehicle drifts from its lane while the turn signals are not operating. The system operates at speeds above 60km/h, and will vibrate the steering wheel and flash the lane departure warning light.

### **Lane Departure Prevention**

Lane Departure Prevention uses front camera to issue an alert if the vehicle drifts from its lane while turn signals are not operating. The system operates at speeds above 60km/h, and will vibrate the steering wheel and flash lane departure warning light. The vehicle will also apply the brakes on one side to help return the vehicle to the centre of the travelling lane.

### **Forward Collision Mitigation<sup>3</sup>**

Forward Collision Mitigation system with pedestrian detection, cyclist detection and junction assist detects obstructions ahead and issues a visual and audible alert when there is a danger of collision and automatically applies the brakes to avoid collision or reduce impact speed/severity.

### **Blind Spot Warning<sup>2</sup> & Lane Change Assist<sup>2</sup>**

Blind spot Warning uses the rear side radar sensors to detect another vehicle travelling or overtaking in the next lane behind. The system operates at speeds above 10km/h, and will illuminate the BSW warning light in the corresponding side mirror when a vehicle is in the detection zone. If driver activates the turn signal towards the corresponding hazard, the BSW lamp will blink and audible alert will sound twice.

### **Multi Around Monitor<sup>\*</sup>**

Multi Around Monitor provides a 360° birds-eye view of your car. The view from cameras mounted on the front, rear and sides of the vehicle (including birds-eye view) can be displayed in various combinations to reveal what is in blind spots and help you park more safely.

### **Rear View Camera**

The Rear View Camera system automatically shows a rear view of the vehicle when the selector lever is placed in the 'R' position. The rear view image is displayed on the Smartphone-link Display Audio screen, and includes predictive guidelines based on steering wheel position.

### **Adaptive Cruise Control**

Adaptive Cruise Control uses radar technology to detect any cars in the lane ahead and adjusts the speed of your car accordingly while maintaining a safe distance set by you.

### **Driver Attention Alert**

Driver Attention Alert system monitors driving style and steering behaviour over a period of time, detecting changes to normal driving pattern. When the system detects that driver attention has deteriorated, audible and visual warnings are signaled to the driver suggesting 'take a break'.

### **Traffic Sign Recognition**

Traffic Sign Recognition uses front camera to read speed limit signs and display the most recently recognised value in the multi-information display, and in the head-up display if equipped. If the vehicle exceeds the displayed speed limit value, the displayed value will begin to blink to warn the driver.

### **Hill Start Assist**

Steep city streets or congested shopping mall ramps are no longer a problem with Mitsubishi's Hill Start Assist technology. It prevents the car from rolling backwards by maintaining braking force to give you time to move your foot from brake to accelerator.

### **Hill Descent Control**

Drive downhill safely with peace of mind. Hill Descent Control automatically applies the brakes when travelling downhill to maintain vehicle speed so you can focus on steering.

### **MI-PILOT<sup>\*</sup>**

MI-PILOT adds extra functionality to Adaptive Cruise Control with features such as Lane Keep Assist to keep the vehicle near the centre of the lane; Traffic Jam Assist which allows Adaptive Cruise Control to automatically reengage after coming to a complete stop within a short time period; and Speed Limit Assist using Traffic Sign Recognition which prompts automatic adjustment to new speed zones with a one-touch acceptance/activation when using Adaptive Cruise Control.

### **Predictive Forward Collision Warning<sup>3</sup>**

Predictive Forward Collision warning uses the front radar to detect sudden braking of the vehicle traveling ahead of the vehicle directly in front. The system operates at speeds above 5km/h and will flash a warning light and sound an audible alert.

<sup>\*</sup>Exceed, Exceed Tourer & GSR models only. <sup>1</sup>Please drive safely and never rely solely on these systems while driving. Drivers are fully responsible for their own safe driving. <sup>2</sup>Aspire, Exceed & Exceed Tourer and GSR models only. <sup>3</sup>Do not rely solely on this system, which may not detect all moving vehicles in certain conditions. <sup>2</sup>The detection and control capabilities of BSW and LCA are supplementary only and do not warn you of vehicles in blind spot every situation. BSW and LCA may not activate in some situations. <sup>3</sup>The detection and control capabilities of FCM are supplementary only and do not prevent collisions in every situation. Please read the operation manual carefully and be aware of these limitations.

# KEY SPECIFICATIONS

KEY	■	Standard
	□	Optional
	-	Not available

## MECHANICAL

	PETROL 2WD				PETROL AWD					PLUG-IN HYBRID EV AWD					
	ES 5 SEAT	LS 5+2 SEAT	BLACK EDITION 5+2 SEAT	ASPIRE 5+2 SEAT	ES 5 SEAT	LS 5+2 SEAT	ASPIRE 5+2 SEAT	EXCEED 5+2 SEAT	EXCEED TOURER 5+2 SEAT	ES 5 SEAT	ASPIRE 5 SEAT	EXCEED 5+2 SEAT	EXCEED TOURER 5+2 SEAT	GSR 5+2 SEAT	
	CVT AUTOMATIC									PLUG-IN HYBRID EV					
<b>Engine</b>															
Type	2.5L DOHC 4-cylinder Direct-Injection									4B12 2.4L DOHC 4-cylinder MPI VVT					
Size (L)	2.5									2.4					
Compression ratio	12.0:1									11.8:1					
Displacement (cc)	2488									2360					
Bore x Stroke (mm)	89.0 x 100.0									88.0 x 97.0					
Maximum Power (kW@rpm)	135 @ 6000									98 @ 5000					
Maximum Torque (Nm@rpm)	244 @ 3600									195 @ 4300					
Front Electric Motor (Max. Output kW)	-									85					
Rear Electric Motor (Max. Output kW)	-									100					
System Max Power (kW)	-									185					
System Max Torque (Nm)	-									450					
Fuel Type	Unleaded (minimum 91 RON recommended)									Unleaded (minimum 91 RON recommended)					
Fuel consumption (ADR 81/02 per 100km)*	7.5	7.7	7.7	7.7	7.8	8.1	8.1	8.1	8.1	1.5					
CO2 - g/km	170	174	174	174	177	185	185	185	185	35					
Fuel tank capacity (L)	55									56					
<b>Transmission</b>															
Type	CVT Automatic									Single speed transaxle					
Number of speeds	8									1					
Paddle shift	■									-					
Preset ratios	2.631 - 0.390									-					
Gear ratio 1st	2.631									-					
2nd	1.756									-					
3rd	1.293									-					
4th	1.009									-					
5th	0.799									-					
6th	0.635									-					
7th	0.504									-					
8th	0.390									-					
Reverse	1.960									-					
Final drive ratio	5.694									-					
Super-All Wheel Control (S-AWC)	-									■					
Active Yaw Control (AYC)	■									■					
<b>Chassis</b>															
Front brakes	Ventilated disc									Ventilated disc					
	320mm	350mm			320mm	350mm				350mm					
Rear brakes	Disc									Disc					
	292mm	330mm			292mm	330mm				330mm					
Front suspension	Macpherson strut with stabiliser bar									Macpherson strut with stabiliser bar					
Rear suspension	Multi-link with stabiliser bar									Multi-link with stabiliser bar					
<b>Wheels and Tyres</b>															
Wheel type	Alloy									Alloy					
	Silver finish		Black	Two tone	Silver finish		Two tone			Silver finish		Two tone		Alloy	
Wheel size (inches)	18 x 7.5J		20 x 8J	20 x 8J	18 x 7.5J		20 x 8J			18 x 7.5J		20 x 8J		Black	
Tyre size	235/60R18 103H		255/45R20 101W		235/60R18 103H		255/45R20 101W			235/60R18 103H		255/45R20 101W		255/45R20 101W	
Spare wheel type	Full size - Alloy		Space saver			Full size - Alloy		Space saver			Tyre repair kit (no spare wheel fitted)				
<b>EV System</b>															
Battery Type	-									Li-ion					
Battery Capacity (KWh)	-									20					
Battery Voltage (V)	-									350					
Variable mode regenerative braking system (RBS)	-									■					
Innovative Pedal Operation mode	-									■					
Charging time - Mode 4 DC Rapid Charger (min)	-									38					
Charging time - Mode 3 AC 15A Fast Charger (hrs)	-									6.5*					
Charging time - Mode 2 AC 240V, 10A (hrs)	-									9.5*					
Charging cable - Mode 3 AC 15A	-									■					
Charging cable - Mode 2 AC 240V, 8A-10A	-									■					
High voltage cut-off system	-									■					
Acoustic Vehicle Alert System (AVAS)	-									■					
V2G/V2H ready	-									■					



	PETROL 2WD				PETROL AWD					PLUG-IN HYBRID EV AWD					
	ES 5 SEAT	LS 5+2 SEAT	BLACK EDITION 5+2 SEAT	ASPIRE 5+2 SEAT	ES 5 SEAT	LS 5+2 SEAT	ASPIRE 5+2 SEAT	EXCEED 5+2 SEAT	EXCEED TOURER 5+2 SEAT	ES 5 SEAT	ASPIRE 5 SEAT	EXCEED 5+2 SEAT	EXCEED TOURER 5+2 SEAT	GSR 5+2 SEAT	
<b>AUDIO &amp; MULTIMEDIA</b>	<b>Audio &amp; Multimedia</b>														
	Smartphone link Display Audio (SDA) with touch screen	■	■	■	■	■	■	■	■	■	■	■	■	■	■
	Screen size (inches)	8	9	9	9	8	9	9	9	9	9	9	9	9	9
	Android Auto	■	■	■	■	■	■	■	■	■	■	■	■	■	■
	Apple CarPlay	■	■	■	■	■	■	■	■	■	■	■	■	■	■
	Wireless Apple CarPlay	-	■	■	■	-	■	■	■	■	■	■	■	■	■
	Satellite navigation	-	■	■	■	-	■	■	■	■	■	■	■	■	■
	BOSE Premium audio	-	-	-	-	-	-	-	■	■	-	-	■	■	■
	Speakers	6	6	6	6	6	6	6	10	10	6	6	9	9	9
	Subwoofer	-	-	-	-	-	-	-	■	■	-	-	■	■	■
	Digital Audio Broadcast (DAB) radio	■	■	■	■	■	■	■	■	■	■	■	■	■	■
	Bluetooth connectivity with voice control & audio streaming	■	■	■	■	■	■	■	■	■	■	■	■	■	■
	AM/FM radio	■	■	■	■	■	■	■	■	■	■	■	■	■	■
USB input	2	2	2	2	2	2	2	2	2	2	2	2	2	2	
<b>COMFORT AND CONVENIENCE</b>	<b>Comfort and Convenience</b>														
	One touch keyless entry	-	■	■	■	-	■	■	■	■	-	■	■	■	■
	One touch start system	■	■	■	■	■	■	■	■	■	■	■	■	■	■
	Remote entry with central door locking	■	■	■	■	■	■	■	■	■	■	■	■	■	■
	Multifunction steering wheel controls	■	■	■	■	■	■	■	■	■	■	■	■	■	■
	Tilt & telescopic steering column	■	■	■	■	■	■	■	■	■	■	■	■	■	■
	Auto up/down driver control - all windows	-	■	■	■	-	■	■	■	■	-	■	■	■	■
	Auto up/down driver control - driver side window	■	-	-	-	■	-	-	-	-	■	-	-	-	-
	Side and rear window demisters	■	■	■	■	■	■	■	■	■	■	■	■	■	■
	Electric sunroof with slide and tilt	-	-	-	-	-	-	-	■	■	-	-	■	■	■
	Pull-up sunshade in rear door	-	-	-	-	-	-	-	-	-	-	-	■	■	■
	Power tailgate	-	-	-	■	-	-	■	■	■	-	-	■	■	■
	Hands-free Tailgate Open	-	-	-	-	-	-	-	■	■	-	-	■	■	■
	Cargo Cover	-	-	Retractable	-	-	-	Retractable	-	-	-	-	Retractable	-	-
	Smartphone wireless charger	-	■	■	■	-	■	■	■	■	-	■	■	■	■
	Accessory socket (12V)	2	2	2	2	2	2	2	2	2	2	1	1	1	1
	Second row seat USB power supply	-	2	2	2	-	2	2	2	2	-	2	2	2	2
	240V/1500W power outlets	-	-	-	-	-	-	-	-	-	-	2	2	2	2
	Programmable charge schedule	-	-	-	-	-	-	-	-	-	■	■	■	■	■
	Programmable climate control schedule	-	-	-	-	-	-	-	-	-	■	■	■	■	■
<b>Air Conditioning</b>	<b>Air Conditioning</b>														
	Climate control (No of zones)	2	2	2	2	2	2	2	3	3	2	2	3	3	3
	Rear zone climate control	-	-	-	-	-	-	-	■	■	-	-	■	■	■
	Rear air vents	■	■	■	■	■	■	■	■	■	■	■	■	■	■
	Dust and pollen filter	■	■	■	■	■	■	■	■	■	■	■	■	■	■
<b>EXTERIOR</b>	<b>Exterior</b>														
	Door handles	-	-	-	-	Body colour	-	-	-	■	-	-	Body colour	-	-
	Two-tone body colour	-	-	-	-	-	-	-	-	■	-	-	-	■	■
	Privacy glass	-	■	■	■	-	■	■	■	■	-	■	■	■	■
	Roof rails	-	■	-	■	-	■	■	■	■	-	■	■	■	■
	Rear spoiler	■	■	■	■	■	■	■	■	■	■	■	■	■	■
	Wheel arch moulding	-	-	-	-	Material black	-	-	-	-	-	-	Material black	-	-
	<b>Lights</b>														
	Headlights low beam	-	-	-	-	LED	-	-	-	-	-	-	LED	-	-
	Headlights high beam	-	-	-	-	LED	-	-	-	-	-	-	LED	-	-
	Headlight levelling function	Manual	Manual	Manual	Auto	Manual	Manual	Auto	Auto	Auto	Manual	Auto	Auto	Auto	Auto
	Daytime Running Lights (DRL)	-	-	-	-	LED	-	-	-	-	-	-	LED	-	-
	Fog lights (front)	-	LED	LED	LED	-	LED	LED	LED	LED	-	LED	LED	LED	LED
	Fog lights (rear)	LED	LED	LED	LED	LED	LED	LED	LED	LED	LED	LED	LED	LED	LED
	Brake lights	-	-	-	-	LED	-	-	-	-	-	-	LED	-	-
<b>Door Mirrors</b>															
Electric adjustment	■	■	■	■	■	■	■	■	■	■	■	■	■	■	
Electric fold control	-	■	■	■	-	■	■	■	■	-	■	■	■	■	
Heating function	-	■	■	■	-	■	■	■	■	-	■	■	■	■	
Integrated turn indicator	-	■	■	■	■	■	■	■	■	-	■	■	■	■	
Finish	Body colour		Black	-	Body colour		-	-	-	Body colour		-	Black	-	
<b>INTERIOR</b>	<b>Styling</b>														
	Leather bound steering wheel	-	■	■	■	-	■	■	■	■	-	■	■	■	■
	Heated steering wheel	-	-	-	-	-	-	-	■	■	-	-	■	■	■
	Leather bound gearshift	-	■	■	■	-	■	■	■	■	-	■	■	■	■
	Carpet floor covering	■	■	■	■	■	■	■	■	■	■	■	■	■	■
	<b>Seating</b>														
	Leather appointed seats	-	-	-	-	-	-	-	■	■	-	-	■	■	■
	Microsuede seat trim with synthetic leather bolster	-	-	■	■	-	-	■	-	-	-	■	-	-	-
	Cloth seat trim	■	■	-	-	■	■	-	-	-	■	-	-	-	-
	Heated front seats	-	-	■	■	-	-	■	■	■	-	■	■	■	■
Driver's seat power adjustment	-	-	■	■	-	-	■	■	■	-	■	■	■	■	

		PETROL 2WD				PETROL AWD					PLUG-IN HYBRID EV AWD					
		ES 5 SEAT	LS 5+2 SEAT	BLACK EDITION 5+2 SEAT	ASPIRE 5+2 SEAT	ES 5 SEAT	LS 5+2 SEAT	ASPIRE 5+2 SEAT	EXCEED 5+2 SEAT	EXCEED TOURER 5+2 SEAT	ES 5 SEAT	ASPIRE 5 SEAT	EXCEED 5+2 SEAT	EXCEED TOURER 5+2 SEAT	CSR 5+2 SEAT	
<b>INTERIOR</b>	Driver's seat manual adjustment	■	■	—	—	■	■	—	—	—	■	—	—	—	—	
	Driver's seat lumbar adjustment	■	■	■	■	■	■	■	■	■	■	■	■	■	■	
	Driver's seat memory function	—	—	—	—	—	—	—	■	■	—	—	■	■	■	
	Driver's seat massage function	—	—	—	—	—	—	—	—	■	■	—	—	■	■	
	Front passenger's seat power adjustment	—	—	—	—	—	—	—	■	■	—	—	—	■	■	
	Front passenger's seat manual adjustment	■	■	—	■	■	■	—	—	—	■	■	—	—	—	
	Front passenger's seat memory function	—	—	—	—	—	—	—	■	■	—	—	—	■	■	
	Front passenger's seat massage function	—	—	—	—	—	—	—	—	■	■	—	—	■	■	
	2nd row centre armrest with cupholders	■	■	■	■	■	■	■	■	■	■	■	■	■	■	
	2nd row split folding function	—	—	—	—	40:20:40	—	—	—	—	—	—	40:20:40	—	—	
	2nd row slide and recline adjustment	—	■	■	■	—	■	■	■	■	—	—	—	■	■	
	2nd row recline adjustment	■	■	■	■	■	■	■	■	■	■	■	■	■	■	
	2nd row seat with heated cushion and back	—	—	—	—	—	—	—	—	—	—	—	—	■	■	
	One touch fold seat storage	■	■	■	■	■	■	■	■	■	■	■	■	■	■	
	3rd row split folding function	—	■	■	■	—	■	■	■	■	■	■	■	—	—	
	3rd row recline adjustment	—	■	■	■	—	■	■	■	■	—	—	■	■	■	
	<b>Storage</b>															
	Centre console with storage box and lid	■	■	■	■	■	■	■	■	■	■	■	■	■	■	■
	Cup holders	4	4	4	4	4	4	4	4	4	4	4	4	4	4	
	Bottle holders	4	4	4	6	6	6	6	6	6	6	4	6	6	6	
	Sunglasses storage	■	■	■	■	■	■	■	■	■	■	■	■	■	■	
	Door pockets - front and rear	■	■	■	■	■	■	■	■	■	■	■	■	■	■	
	Seat back pocket - driver and passenger	■	■	■	■	■	■	■	■	■	■	■	■	■	■	
	Rear floor storage box	—	—	—	—	—	—	—	—	—	—	■	■	—	—	
	Charge cable case	—	—	—	—	—	—	—	—	—	—	—	—	■	■	
	<b>Exterior Dimensions</b>															
	Overall length (mm)					4710					4710					
	Overall width (mm)					1862					1862					
	Overall height (mm)	1740		1745		1740		1745			1740		1745			
	Wheelbase (mm)					2706					2706					
	Turning circle, kerb to kerb (m)					11.2					11.2					
	Approach angle (degrees)	18		18.3		18		18.3			18		18.3			
	Departure angle (degrees)	22.1		22.2		22.1		22.2			21.9		22.2			
Ramp breakover angle (degrees)	17.8		18.1		17.8		18.1			17.6		18.0				
Ground clearance (mm) - minimum, unladen	205		210		205		210			199		203				
<b>Interior Dimensions</b>																
Front head room (mm)					986					1031						
Front leg room (mm)					1058					1058						
Front shoulder room (mm)					1470					1470						
2nd row head room (mm)					950					993						
2nd row leg room (mm)					1014					968						
2nd row shoulder room (mm)					1420					1420						
3rd row head room (mm)	—		876		—		875			—		841				
3rd row leg room (mm)	—		475		—		474			—		486				
3rd row shoulder room (mm)	—		1300		—		1300			—		1300				
<b>Weights and Capacities</b>																
Kerb mass (kg)	1580	1640	1660	1665	1635	1690	1720	1760	1760	2020	2050	2140	2145	2145		
Gross vehicle mass (GVM) - (kg)	2245	2355	2355	2355	2245	2355	2355	2355	2355	2650	2650	2750	2750	2750		
Gross combination mass (GCM) - (kg)	3845	3955	3955	3955	3845	3955	3955	3955	3955	4250	4250	4350	4350	4350		
Maximum payload (kg)	670	720	695	720	615	665	635	595	595	630	600	610	605	605		
Maximum front axle load (kg)	1210															
Maximum rear axle load (kg)	1365															
Towing capacity - braked (kg)	1600															
Towing capacity - unbraked (kg)	750															
Towing capacity - maximum towball load (kg)	160															
Maximum roof load (kg)	80															
<b>Weights and Capacities</b>																
Seating capacity	5	5+2	5+2	5+2	5	5+2	5+2	5+2	5+2	5+2	5	5	5+2	5+2	5+2	
Capacity (L) - VDA (to top of 2nd row seat back)	485	478		485	478		478			494		461				
Capacity (L) - VDA (to top of 3rd row seat back)	—	163		—	163		163			—		191				
Capacity (L) - VDA (max. capacity to roof - all rear seats folded)	1466	1461		1466	1461		1473			1414		1387				
Cargo room length (mm) - all seats up	941	974		985	974		974			941		442				
Cargo room length (mm) - with all rear seats folded					1717					1717						
Cargo room length (mm) - with 3rd row seats folded					—					974						
Cargo room width (mm)	1380															
Cargo room height (mm)	870															
Width between wheel arches (mm)	1070															

+Australian Standard ADR 81/02. Figures to be used for comparison across vehicles. Driving conditions will affect actual results. ^Charging time will vary depending on the condition of the drive battery, air temperature, electric power consumption of electrical devices during charging and condition of the power source. (such as specifications of the quick charger) This charging time is for when the value of the upper limit of the electrical current on the charger side is 15 A or above. If the value is less than 15 A, the charging time will be longer depending on the value of the electrical current on the charger side. \*Charging time will vary depending on the condition of the drive battery, air temperature, electric power consumption of electrical devices during charging and condition of the power source (such as specifications of the quick charger). This charging time is for when the value of the upper limit of the electrical current on the charger side is 10 A or above. If the value is less than 10 A, the charging time will be longer depending on the value of the electrical current on the charger side.

# OUTLANDER MODEL FEATURES



## ES 2WD PETROL 5 SEAT

### FEATURES:

- 2.5L Direct Injection Petrol Engine
- Active Yaw Control (AYC)
- 5 Drive Modes
- CVT Auto Transmission With Manual Shift Mode
- One Touch Start System
- Paddle Shift
- Electric Park Brake
- 18" Silver Finish Alloy Wheels
- LED Headlights With Manual Levelling Device
- LED Daytime Running Lights (DRL)
- LED Front Turn Signal
- 8 SRS Airbags
- Rear Spoiler LED High Stop Lamp
- Dual Zone Air Conditioning
- 40:20:40 Split Fold 2nd Row Seat With Recline Adjustment
- Active Stability Control (ASC)
- Traction Control
- Terrain Control
- Cruise Control
- Smartphone link Display Audio (SDA) With 8-inch Touchscreen
- 6 Speakers Including 2 Tweeters
- Apple CarPlay
- Android Auto™
- Bluetooth Connectivity With Voice Control & Audio Streaming
- Digital Audio Broadcast (DAB+) Radio
- Cloth Seat Trim
- Full Size Alloy Spare Wheel & Tyre
- Rear LED Fog Lights

### MiTEC Mitsubishi Motors Intuitive Technology

- Forward Collision Mitigation (FCM) With Pedestrian & Cyclist Detection & Junction Assist
- Adaptive Cruise Control (ACC)
- Blind Spot Warning (BSW) & Lane Change Assist (LCA)
- Blind Spot Warning
- Emergency Lane Assist (ELA)
- Lane Departure Warning (LDW)
- Lane Departure Prevention (LDP)
- Rear View Camera
- Hill Start Assist
- Hill Descent Control
- Driver Attention Alert
- Traffic Sign Recognition (TSR)
- Trailer Stability Assist (TSA)
- Rear Automatic Emergency Braking
- Rear Cross Traffic Alert
- Auto High Beam System (AHB)
- Auto Dusk Sensing Headlights

## ES AWD PETROL 5-SEAT

### INCLUDES ALL ES 2WD 5-SEAT PLUS:

- Super All Wheel Control (S-AWC)
- 6 Drive Modes



## LS 2WD PETROL 5+2 SEAT

### INCLUDES ALL ES 2WD 5 SEAT FEATURES (EXCLUDING FULL SIZE SPARE) PLUS:

- Privacy Glass
- LED Front Fog Lights
- 5+2 Seat Capacity
- Silver Roof Rails
- Leather Steering Wheel
- Leather Gearshift Knob
- Smart Key Keyless Operation System
- Smartphone Wireless Charger
- 2 x USB Power Socket In Rear Console
- Electrochromatic Rear View Mirror
- Space Saver Spare Wheel
- 40:20:40 Split Fold 2nd Row Seat With Slide & Recline Adjustment
- Smartphone link Display Audio (SDA) With 9-inch Touchscreen & Satellite Navigation + Wireless Apple CarPlay

### MiTEC Mitsubishi Motors Intuitive Technology

- Auto Rain Sensing Wipers

## LS AWD PETROL 5+2 SEAT

### INCLUDES ALL LS 2WD 5+2 SEAT FEATURES PLUS:

- Super All Wheel Control (S-AWC)
- 6 Drive Modes



## 2WD BLACK EDITION 5+2 SEAT

### INCLUDES ALL LS 2WD 5+2 SEAT FEATURES PLUS:

- 20" Black Alloy Wheels
- Gloss Black Front & Rear Under Garnish
- Gloss Black Mirror Doors
- Gloss Black Grille Garnish
- Microsuede Seat Trim With Synthetic Leather Bolster
- Power Driver Seat - Slide, Recline, Height & Lumbar Support
- Black Laser Etched Shift Panel
- Black Headlining
- Black Front Pillar Trims
- Heated Driver & Front Passenger Seat with Seat Heater in Cushion & Back

Excludes Roof Rails.



## ASPIRE 2WD PETROL 5+2 SEAT

### INCLUDES ALL LS 2WD 5+2 SEAT FEATURES PLUS:

- 20" Two-Tone Alloy Wheels
- Microsuede Seat Trim With Synthetic Leather Bolster
- LED Headlights With Automatic Levelling Device
- Adaptive Driving Beam (ADB)
- Power Driver Seat - Slide, Recline, Height & Lumbar Support
- Heated Driver & Front Passenger Seat With Seat Heater in Cushion & Back
- Head-Up Display
- Power Tailgate With One Touch Open

### MiTEC Mitsubishi Motors Intuitive Technology

- Multi Around Monitor (MAM)

## ASPIRE AWD PETROL 5+2 SEAT

### INCLUDES ALL ASPIRE 2WD 5+2 SEAT FEATURES PLUS:

- Super All Wheel Control (S-AWC)
- 6 Drive Modes



## EXCEED AWD PETROL 5+2 SEAT

### INCLUDES ALL ASPIRE AWD 5+2 SEAT FEATURES PLUS:

- Panoramic Sunroof - Front Tilt/Slide With One Touch Open & Close. Rear Fixed.
- Power Tailgate With One Touch Open & Hands-Free Operation
- Black Leather Appointed Seat Trim
- Light Grey Leather Appointed Seat Trim (Optional)
- Power Passenger Seat - Slide, Recline, Height & Lumbar Support
- Driver & Passenger Front Seat With Memory
- Aluminium Gearshift Trim Panel
- Pull-Up Roll Sunshade In Rear Door Trim
- Tri-Zone Climate Control With Rear Climate Control Panel
- Unique Illumination In Front Door Trim
- BOSE™ Premium Sound System With 10 Speakers
- 12.3-inch Digital Driver Display
- Heated Steering Wheel
- Front LED Sequential Indicators
- MI-PILOT



## EXCEED TOURER AWD PETROL 5+2 SEAT

### INCLUDES ALL EXCEED AWD 5+2 SEAT FEATURES PLUS:

- Two-Tone Exterior Body Colour
- Two-Tone High Grade Leather Appointed Seat Trim
- Driver & Passenger Seat Massage Function
- Heated Steering Wheel
- Heated rear seats
- MI-PILOT



OUTLANDER

# PLUG-IN HYBRID EV MODEL FEATURES



## ES AWD PLUG-IN HYBRID EV 5 SEAT

### FEATURES:

- 2.4L Direct Injection Petrol Engine
- 4th Generation Plug-in Hybrid EV Powertrain
- 20kWh Lithium-ion Drive Battery
- Super All-Wheel Control (S-AWC)
- Variable Mode Regenerative Braking System
- Innovative Pedal Operation Mode (Single-Pedal Driving)
- 7 Drive Modes - ECO, Normal, Tarmac, Gravel, Mud, Snow and Power
- EV Charging and HVAC Scheduler
- Mode 4 DC Fast Charging Port (V2G Compatible)
- Mode 3 Charging Cable
- Mode 2 AC Charging Cable
- One Touch Start System
- Paddle Shift
- Electric Park Brake
- 18" Silver Finish Alloy Wheels
- LED Headlights With Manual Levelling Device
- LED Daytime Running Lights (DRL)
- LED Front Turn Signal
- Rear Spoiler LED High Stop Lamp
- Dual Zone Air Conditioning
- Active Stability Control (ASC)
- 8 SRS Airbags
- Cruise Control
- Smartphone link Display Audio (SDA) With 9" Touchscreen & Satellite Navigation
- 12.3-inch Digital Driver Display
- 6 Speakers Including 2 Tweeters
- Wireless Apple CarPlay
- Android Auto
- Bluetooth Connectivity With Voice Control & Audio Streaming
- Digital Audio Broadcast (DAB+) Radio
- Cloth Seat Trim
- Acoustic Vehicle Alert System
- Rear Seat Alert
- 40:20:40 Split Fold 2nd Row Seat With Recline Adjustment
- Tyre Repair & Inflation Kit (Replaces Full Size Spare)
- Rear LED Fog Lights

### MiTEC Mitsubishi Motors Intuitive Technology

- Forward Collision Mitigation (FCM) With Pedestrian & Cyclist Detection & Junction Assist
- Adaptive Cruise Control (ACC)
- Blind Spot Warning (BSW)
- Blind Spot Warning
- Emergency Lane Assist (ELA)
- Lane Departure Warning (LDW)
- Lane Departure Prevention (LDP)
- Rear View Camera
- Hill Start Assist
- Hill Descent Control
- Driver Attention Alert
- Traffic Sign Recognition (TSR)
- Trailer Stability Assist (TSA)
- Rear Automatic Emergency Braking
- Rear Cross Traffic Alert
- Auto High Beam
- Auto Dusk Sensing Headlights



## ASPIRE AWD PLUG-IN HYBRID EV 5 SEAT

### INCLUDES ALL ES AWD PLUG-IN HYBRID EV 5 SEAT FEATURES PLUS:

- 20" Two-Tone Alloy Wheels
- Smart Key Keyless Operation System
- Head-Up Display
- Smartphone Wireless Charger
- 240V/1500W Power Outlets
- Privacy Glass
- Electrochromatic Rear View Mirror
- Roof Rails
- LED Headlights With Automatic Levelling Device
- LED Front Fog Lights
- Leather Steering Wheel
- Leather Gearshift Knob
- Microsuede Seat Trim With Synthetic Leather Bolster
- Heated Driver & Front Passenger Seat
- Power Driver Seat - Slide, Recline, Height & Lumbar Support
- Power Tailgate With One Touch Open

### MiTEC Mitsubishi Motors Intuitive Technology

- Multi Around Monitor (MAM)
- Adaptive Driving High Beam
- Auto Rain Sensing Wipers



## EXCEED AWD PLUG-IN HYBRID EV 5+2 SEAT

### INCLUDES ALL ASPIRE AWD PLUG-IN HYBRID EV 5 SEAT FEATURES PLUS:

- 5+2 Seat Capacity
- BOSE Premium Audio With 9 Speakers
- Panoramic Sunroof - Front Tilt/Slide With One Touch Open & Close. Rear Fixed.
- Pull-up Roll Sunshade In Rear Door Trim
- Power Tailgate With One Touch Open & Hands-Free Operation
- Tri-Zone Climate Control With Rear Climate Control Panel
- Rear Zone Climate Control
- Black Leather Appointed Seat Trim
- Light Grey Leather Appointed Seat Trim (optional)
- Driver & Passenger Front Seat With Memory
- Power Passenger Seat - Slide, Recline, Height & Lumbar Support
- 3rd Row Recline Adjustment
- Unique Illumination In Front Door Trim
- Aluminium Gearshift Trim Panel
- Heated Steering Wheel
- Front LED Sequential Indicators
- MI-PILOT
- Lane Keep Assist (LKA)



## EXCEED TOURER AWD PLUG-IN HYBRID EV 5+2 SEAT

### INCLUDES ALL EXCEED AWD PLUG-IN HYBRID EV 5 SEAT FEATURES PLUS:

- Two-Tone Exterior Body Colour
- Two-Tone High-Grade Leather Appointed Seat Trim
- Driver & Front Passenger Seat Massage Function
- Heated Rear Seats
- MI-PILOT
- Lane Keep Assist (LKA)



## GSR AWD PLUG-IN HYBRID EV 5+2 SEAT

### INCLUDES ALL EXCEED TOURER AWD PLUG-IN HYBRID EV 5+2 SEAT FEATURES PLUS:

- 20" black alloy wheels
- Gloss black front & rear under garnish
- Gloss black grille
- Gloss back door mirrors
- Gloss black roof rail
- Black 'Outlander' bonnet emblem
- Black leather appointed seat trim with silver stitching





# MAKE YOUR MARK. STAY GENUINE.

Make the Outlander truly your own with Mitsubishi Genuine Accessories. Each and every one goes through an extensive program of design, development and stringent testing to ensure they meet all applicable government standards as well as Mitsubishi's own rigorous engineering specifications and performance targets.



**MITSUBISHI**  
**DIAMOND**  
**ADVANTAGE**  
**GENUINE ACCESSORIES**

**NOT GENUINE?  
DON'T RISK IT.**



Tailgate Spoiler



Front Under Garnish



Rear Bumper Garnish



Alloy Wheel 18" (Black Diamond Cut)



Black Alloy Wheel 20"



Engine Hood Emblem (Chrome)



Hood Protector (Tinted)



Side Window Deflectors



Mud Guards



Nudge Bar (Black)



Cargo Barrier



Tow Bar



Electric Trailer Brake Kit



Roof Carrier



Thule Bike Carrier



Floor Mats



All Weather Floor Mats



Roll Sunshade



Cargo Protector



Floor Illumination

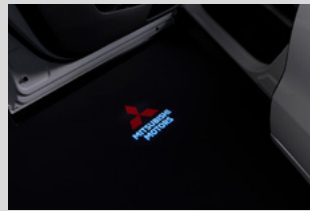

Projection Illumination



PHEV body side decal



PHEV fuel lid



PHEV charging cable bag (charging cable is not included)

Mitsubishi genuine accessories have been designed to maintain the integrity of your vehicle and work with all driving systems. Please ensure if fitting non-genuine accessories that they do not interfere with any of the vehicle safety sensors as this may lead to system malfunction and/or false activation. Some accessories are not offered by Mitsubishi on certain models as they interfere with vehicle safety sensors. GENUINE ACCESSORY WARRANTY Mitsubishi Motors Australia Limited warrants that Genuine Accessories will be free from defects in material under conditions of normal use and service within Australia. When Genuine Accessories are fitted prior to the owner taking delivery of the vehicle, Genuine Accessories are covered by a 36 month or 100,000km Warranty. When Genuine Accessories are fitted after the owner has taken delivery of the new Vehicle, Genuine Accessories are warranted for whichever is the greater of the following • The balance of the 36 months or 100,000km (whichever occurs first) from date of vehicle delivery; or • 12 months or 20,000km (whichever occurs first) from date of fitment. Pictures shown are for illustration purpose and may not be product specific. Please check with your Mitsubishi dealer for specific model application.

## COLOUR



White (S)\*



White Diamond (X)



Sterling Silver (M)\*



Graphite Grey (M)



Red Diamond (X)



Cosmic Blue (P)\*



Black Diamond (X)



Black Diamond/  
Sterling Silver (X)\*\*



White Diamond/  
Black Mica (X)\*\*



Sterling Silver/  
Black Mica (X)\*\*



Graphite Grey/  
Black Mica (X)\*\*



Red Diamond/  
Black Mica (X)\*

(M) Metallic  
(P) Pearlescent  
(X) Prestige

\*Two-tone Exceed Tourer only

†Excludes Black Edition

^Available on GSR

## EXTERIOR DIMENSIONS (MM)

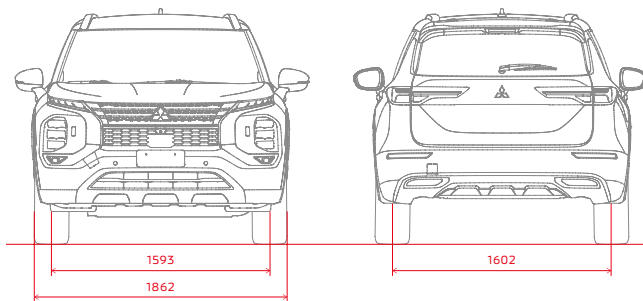
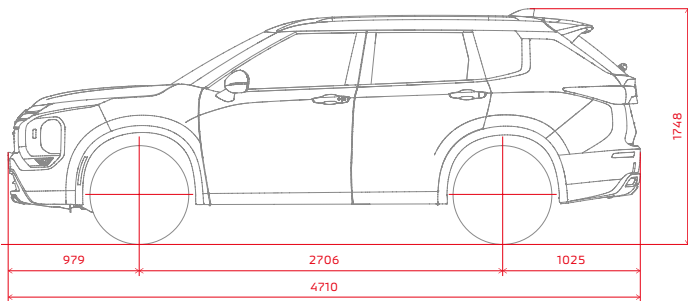

## UPHOLSTERY



**ES/LS**  
Black Cloth



**LS BLACK EDITION/ASPIRE**  
Microsuede Facings With  
Synthetic Leather Bolster



**EXCEED**  
Black Leather Appointed\*  
Light Grey Leather  
Appointed\* (Optional)



**EXCEED TOURER**  
Black/Saddle Tan Two-Tone  
Leather Appointed\*



**GSR**  
Black Leather Appointed\*  
with silver stitching

## AUSTRALIA'S FIRST

**10**  
**YEARS**  
NEW CAR WARRANTY

**10**  
**YEARS**  
CAPPED PRICE SERVICING

# MITSUBISHI DIAMOND ADVANTAGE

WHEN ALL SCHEDULED SERVICES ARE COMPLETED  
AT A MITSUBISHI DEALERSHIP

All Mitsubishi Motors vehicles come with the Mitsubishi Diamond Advantage<sup>#</sup> 10 Years Warranty\* and 10 Years Capped Price Servicing<sup>^</sup> and Roadside Assistance so that no matter where the road takes you, we will be there with you. Excludes Plug-in Hybrid EV drive batteries which are warranted for 8 years / 160,000kms from the date of first registration. Ask your Dealer or visit [mitsubishi-motors.com.au](http://mitsubishi-motors.com.au) to find out more.

\*Leather appointed seats are a combination of genuine and artificial leather and are not wholly leather. # Conditions apply. Excludes Government, Rental and National Business customers. \*Up to 10 years from the date of first registration or 200,000km New Vehicle Warranty (whichever comes first) when all regular services are completed within the specified service intervals at a Mitsubishi Dealership. Otherwise, 5 years from the date of first registration or 100,000km New Vehicle Warranty (whichever comes first) applies. Excludes Plug-in Hybrid EV drive batteries which are warranted for 8 years / 160,000kms from the date of first registration. ^Service conditions apply. 10 year or 150,000km Capped Price Servicing (whichever occurs first). Includes the first 10 regular services (at 15,000km/12 month scheduled intervals). Covers all items specified under the standard "Regular Service Table" for normal operating conditions detailed in the Periodic Inspection and Maintenance Schedule on the Mitsubishi website. Additional service/repair items (if required) are at additional cost. Once a schedule of Capped Price Servicing costs are set for a model year, they are not changed for the life of the model. Terms and conditions apply. See [www.mitsubishi-motors.com.au/owners/diamond-advantage.html](http://www.mitsubishi-motors.com.au/owners/diamond-advantage.html) page for further information. Always consult your authorised Mitsubishi Dealer for the latest details, options, availability and conditions on New Vehicle warranty. All product illustration and specifications referred to herein are believed to be correct at the time of publication approval. Subject to any applicable Federal, State or Territory Laws or ordinances, which may apply from time to time. Mitsubishi Motors Australia Limited reserves the right, without notice, or obligation, to discontinue or make changes to designs, specifications, colours and material of the options and products referred herein at any time without incurring any liability to any purchase thereof. Mitsubishi Motors Australia Limited. ABN 53 007 870 395 © Mitsubishi Motors Australia Limited. ABN 53 007 870 395 OUT0722 24MY MITO092



**BOOK A TEST DRIVE**



**BUILD AND PRICE**